

Assembly

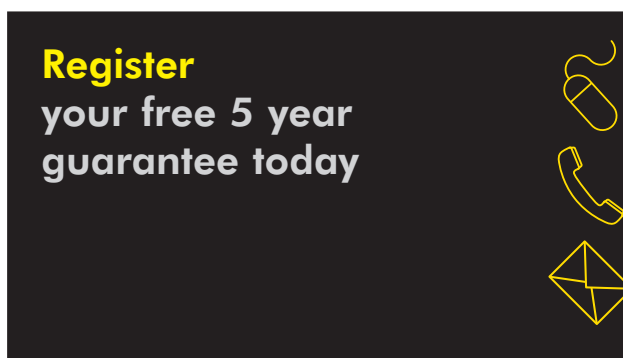
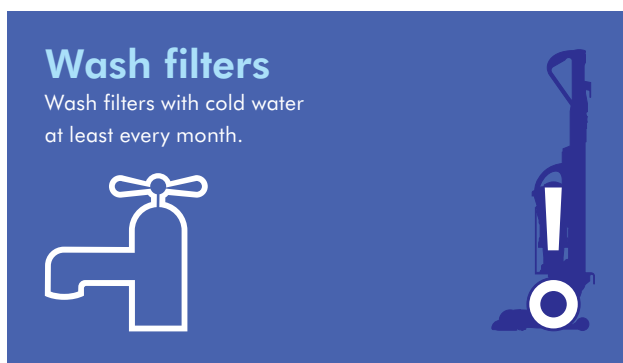
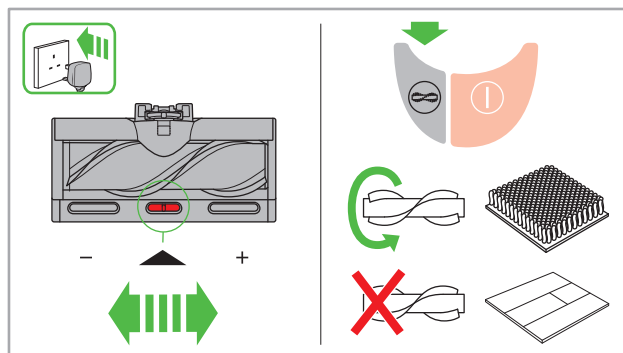
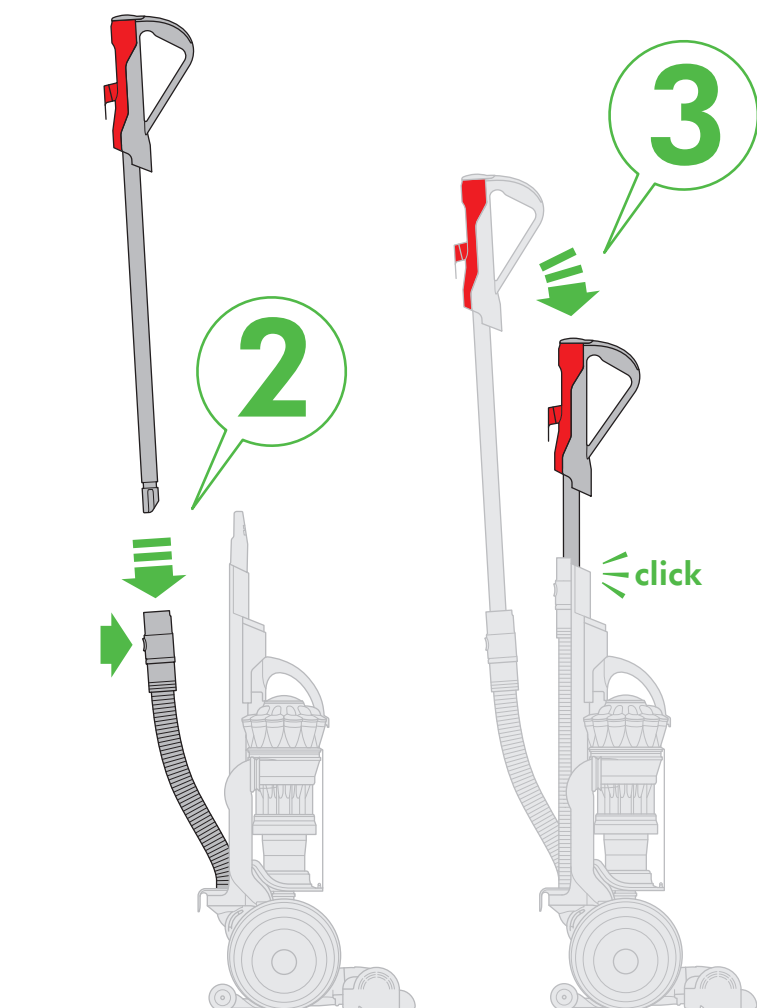
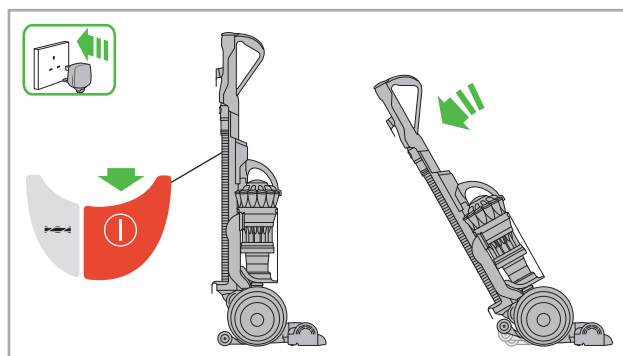
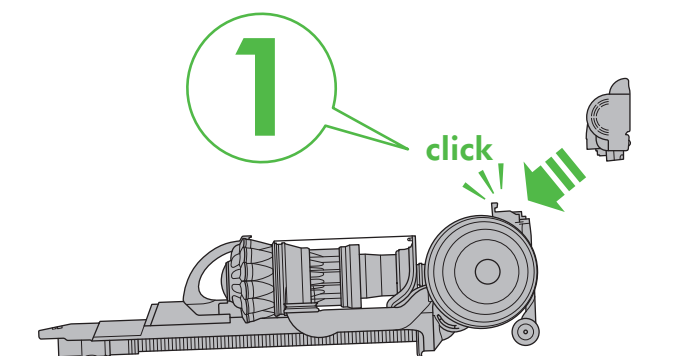

DYSON CUSTOMER CARE

THANK YOU FOR CHOOSING TO BUY A DYSON APPLIANCE.

After registering your 5 year guarantee, your Dyson appliance will be covered for parts and labour for 5 years from the date of purchase, subject to the terms of the guarantee. If you have any queries regarding your Dyson appliance, visit www.dyson.co.uk/support (UK) or www.dyson.ie/support (ROI) for online help, general tips and useful information about Dyson.

Alternatively, you can call the Dyson Helpline with your serial number and details of where/when you bought the appliance.

Dyson contact details

UK:
Website: www.dyson.co.uk/support
Dyson helpline: 0800 298 0298
Email: askdyson@dyson.co.uk
Address: Dyson Technology Limited, Tetbury Hill, Malmesbury, Wiltshire, SN16 0RP

ROI:
Website: www.dyson.ie/support
Dyson helpline: 01 475 7109
Email: askdyson@dyson.ie
Address: Dyson Ireland Limited, Office 2, Central Park, Leopardstown, Dublin 18, Ireland

Your serial number can be found on your rating plate which is behind the clear bin.

Note your serial number for future reference.



This illustration is for example purposes only.

IMPORTANT SAFETY INSTRUCTIONS

BEFORE USING THIS APPLIANCE READ ALL INSTRUCTIONS AND CAUTIONARY MARKINGS IN THIS MANUAL AND ON THE APPLIANCE

When using an electrical appliance, basic precautions should always be followed, including the following:

WARNING

These warnings apply to the appliance, and also where applicable, to all tools, accessories, chargers or mains adaptors. TO REDUCE THE RISK OF FIRE, ELECTRIC SHOCK OR INJURY:

1. This Dyson appliance can be used by children aged from 8 years and above and persons with reduced physical, sensory or reasoning capabilities, or lack of experience and knowledge, only if they have been given supervision or instruction by a responsible person concerning use of the appliance in a safe way and understand the hazards involved. Cleaning and user maintenance shall not be made by children without supervision.
2. Do not allow to be used as a toy. Close attention is necessary when used by or near children. Children should be supervised to ensure that they do not play with the appliance.
3. Use only as described in this Dyson Operating Manual. Do not carry out any maintenance other than that shown in this manual, or advised by the Dyson Helpline.
4. Suitable for dry locations ONLY. Do not use outdoors or on wet surfaces.
5. Do not use to pick up water.

3 EASY WAYS TO REGISTER YOUR FREE 5 YEAR GUARANTEE

REGISTER ONLINE 

Visit our website to register your full parts and labour guarantee online.

www.dyson.co.uk/register
www.dyson.ie/register

REGISTER BY PHONE 

Call our dedicated helpline. Open Monday to Friday 8am-8pm & Saturday and Sunday 8am-6pm.

UK: 0800 298 0298
ROI: 01 475 7109

REGISTER BY MAIL 

Complete and return the form to Dyson in the envelope supplied.

6. Do not handle any part of the plug or appliance with wet hands.
7. Do not use with a damaged cable or plug. If the supply cable is damaged it must be replaced by Dyson, its service agent or similarly qualified person in order to avoid a hazard.
8. If the appliance is not working as it should, has received a sharp blow, has been dropped, damaged, left outdoors, or dropped into water, do not use and contact the Dyson Helpline.
9. Contact the Dyson Helpline when service or repair is required. Do not disassemble the appliance as incorrect reassembly may result in an electric shock or fire.
10. Do not stretch the cable or place the cable under strain. Keep the cable away from heated surfaces. Do not close a door on the cable, or pull the cable around sharp edges or corners. Arrange the cable away from traffic areas and where it will not be stepped on or tripped over. Do not run over the cable.
11. Do not unplug by pulling on the cable. To unplug, grasp the plug, not the cable. The use of an extension cable is not recommended.
12. Do not use to pick up flammable or combustible liquids, such as petrol, or use in areas where they or their vapours may be present.
13. Do not pick up anything that is burning or smoking, such as cigarettes, matches, or hot ashes.
14. Keep hair, loose clothing, fingers, and all parts of the body away from openings and moving parts, such as the brush bar. Do not point the hose, wand or tools at your eyes or ears or put them in your mouth.
15. Do not put any object into openings. Do not use with any opening blocked; keep free of dust, lint, hair and anything that may reduce airflow.
16. Use only Dyson recommended accessories and replacement parts.
17. To avoid a tripping hazard wind the cable when not in use.
18. Do not use without the clear bin and filter in place.
19. Do not leave the appliance when plugged in. Unplug when not in use and before servicing.
20. Do not pull or carry by cable or use cable as a handle.
21. Use extra care when cleaning on stairs. Do not work with the appliance above you on the stairs.

22. Turn off all controls before unplugging. Unplug before connecting any tool or accessory.

READ AND SAVE THESE INSTRUCTIONS

This Dyson appliance is intended for household use only.

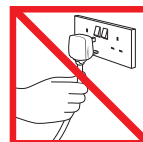

Do not pull on the cable.

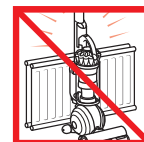

Do not store near heat sources.



Do not use near naked flames.

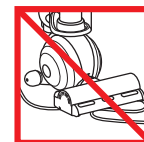

Do not run over the cable.

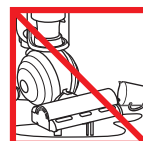

Do not pick up water or liquids.



Do not pick up burning objects.



Do not use above you on the stairs.

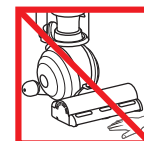

Do not put hands near the brush bar when the appliance is in use.

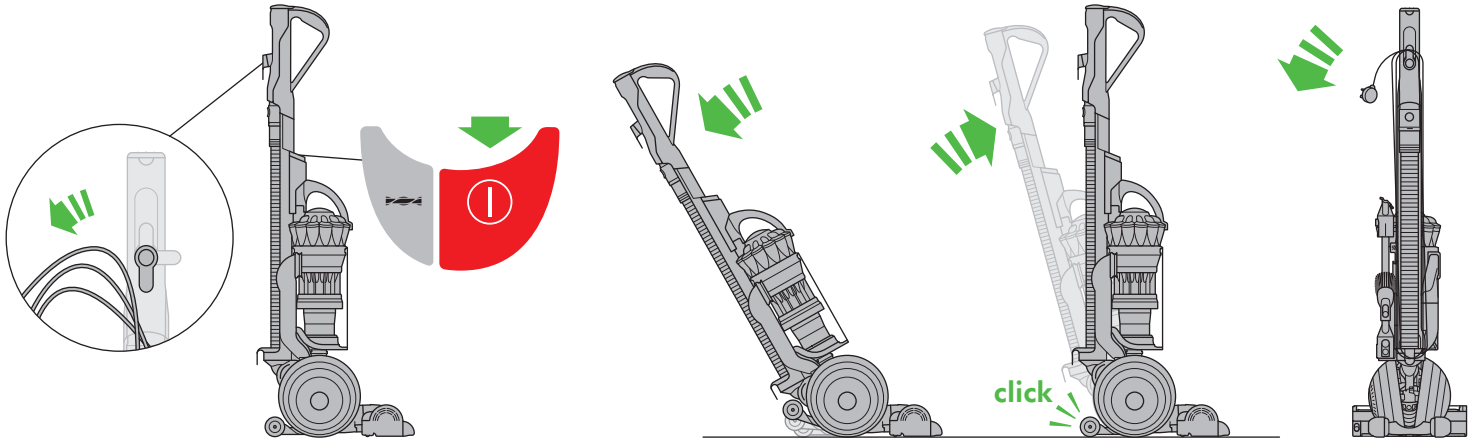
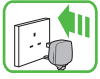

Emptying the clear bin

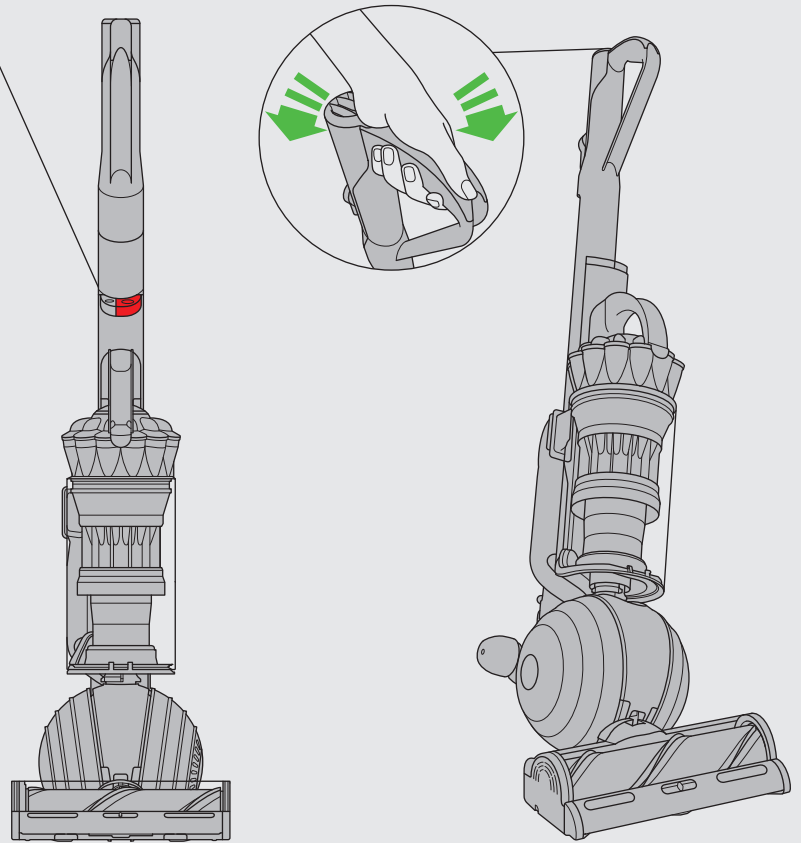
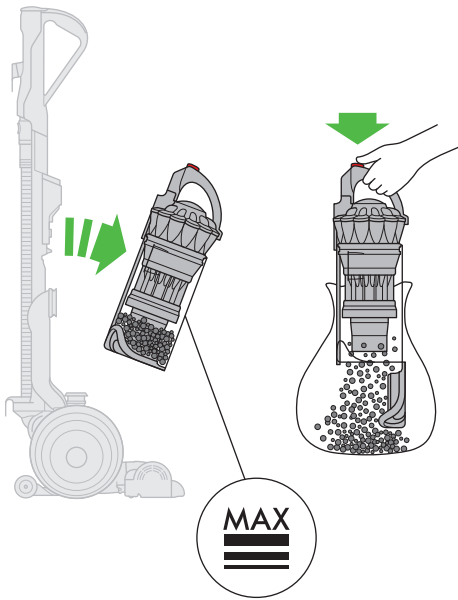
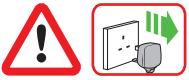

Looking for blockages

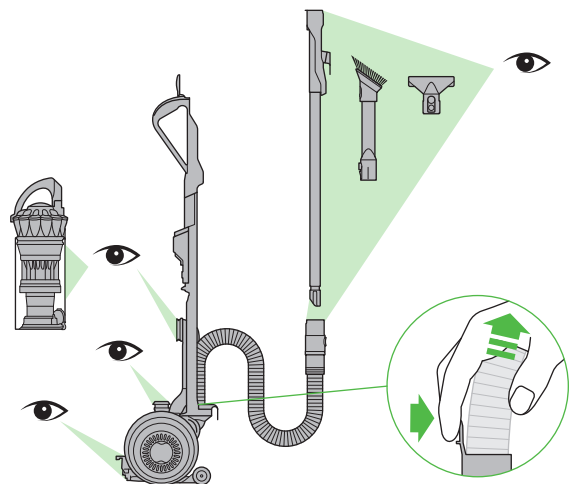
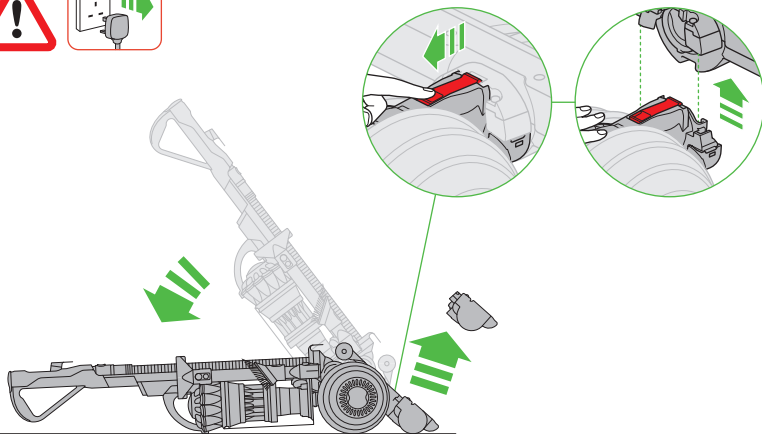

Carrying the appliance

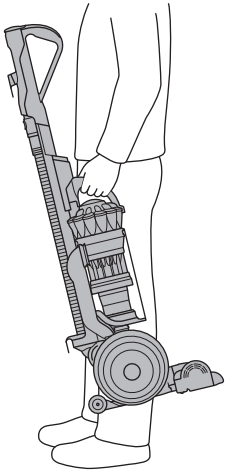

Carpets or hard floors

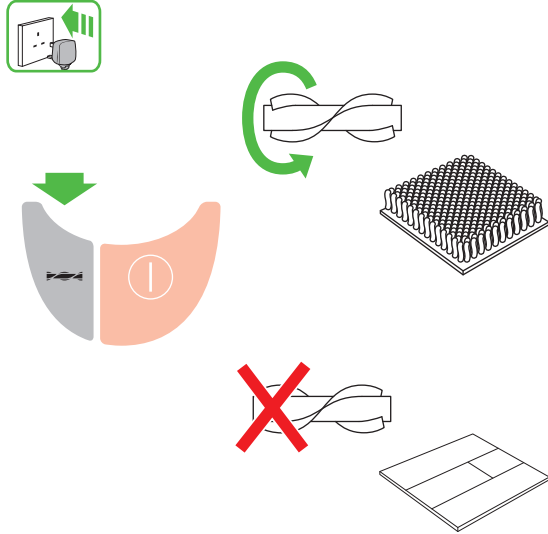

Direct drive cleaner head with suction control

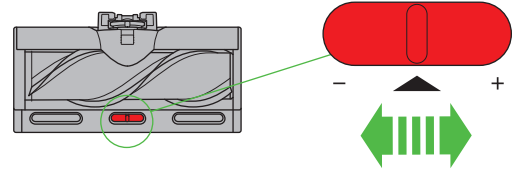

Tool attachments

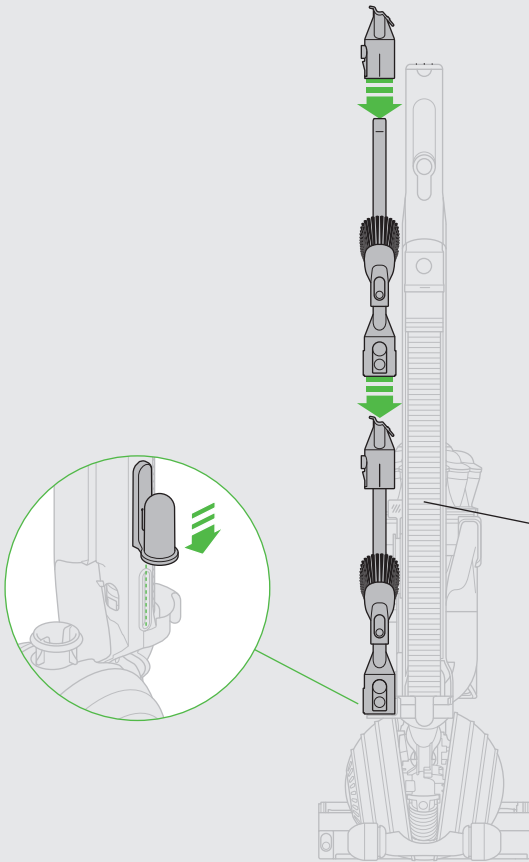
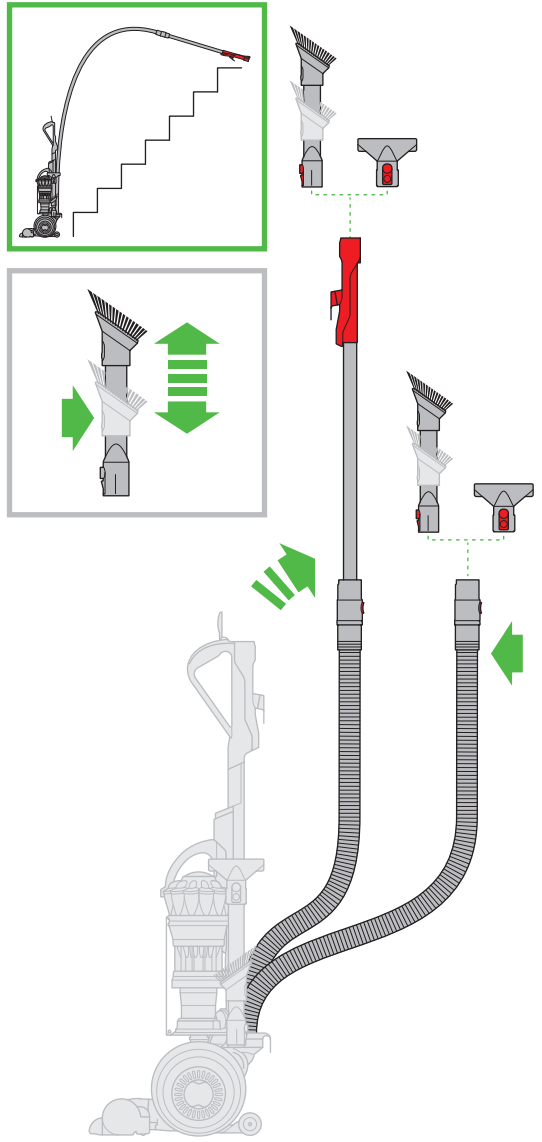

Clearing obstructions

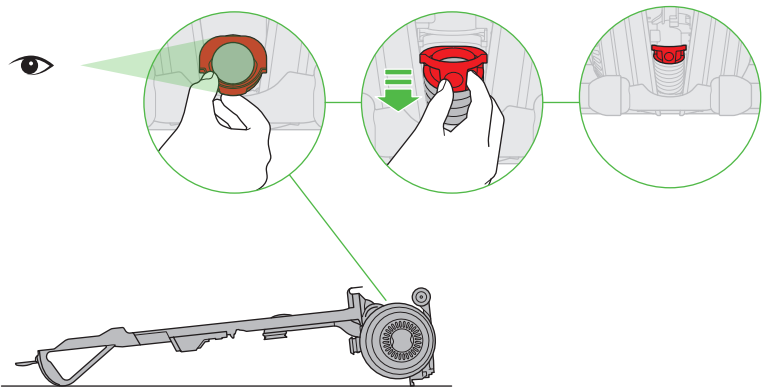
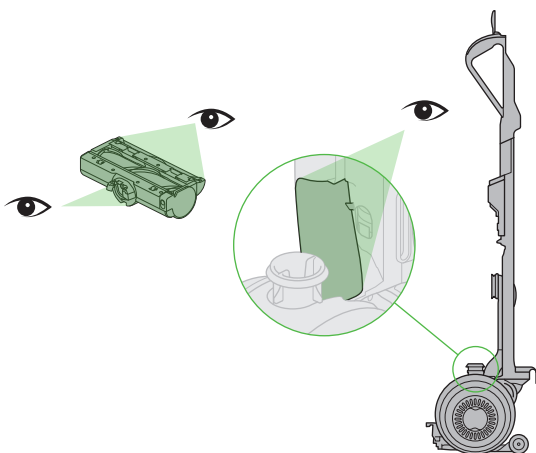





Important!

Wash filters

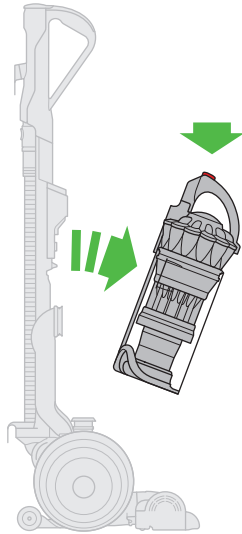
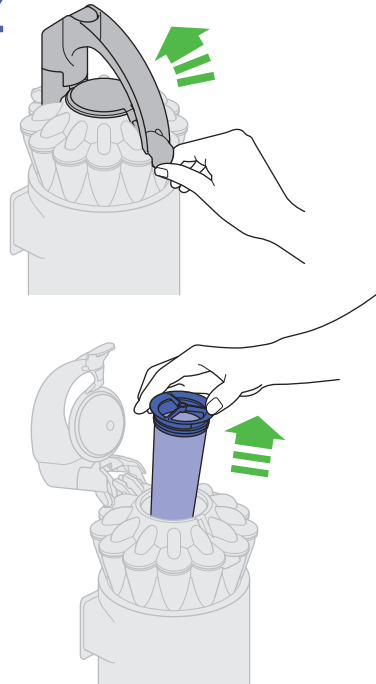
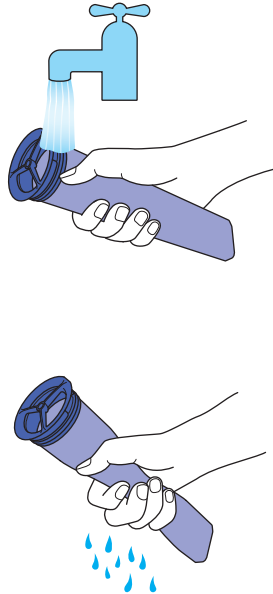

Wash filters with cold water at least once every month.

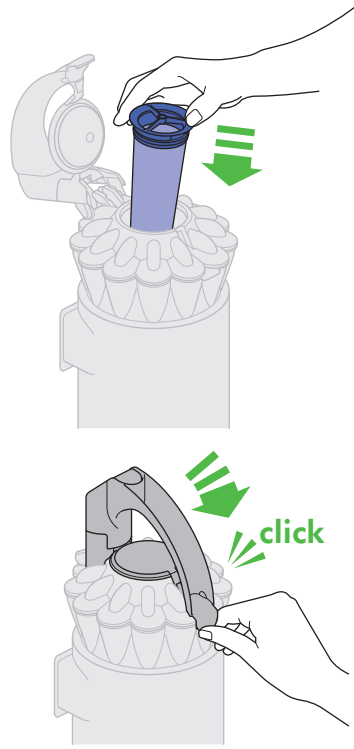
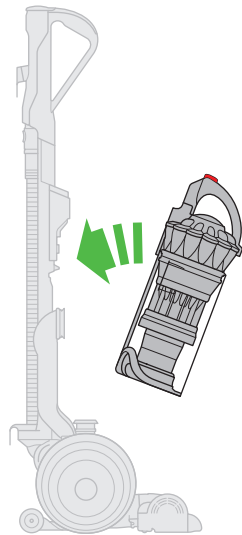
<p>A  </p> <p>1</p> 	<p>2</p> 	<p>3</p> 
<p>4</p>  <p>24 hrs</p>	<p>5</p> 	<p>6</p> 



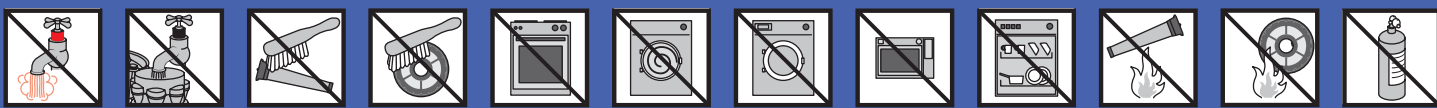
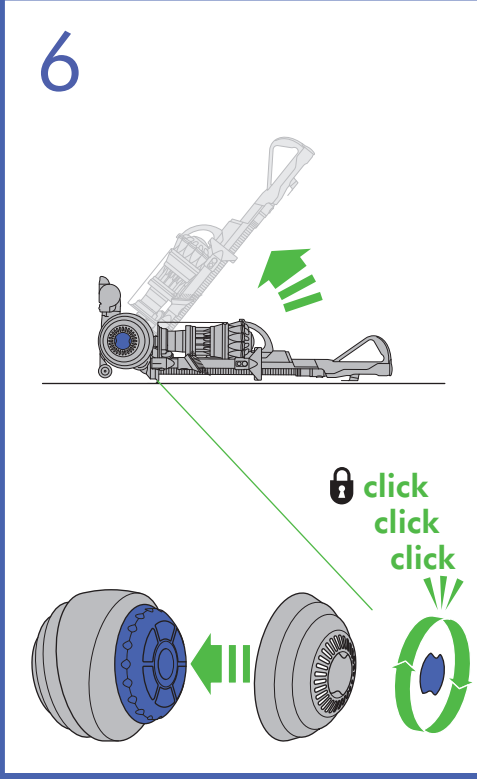
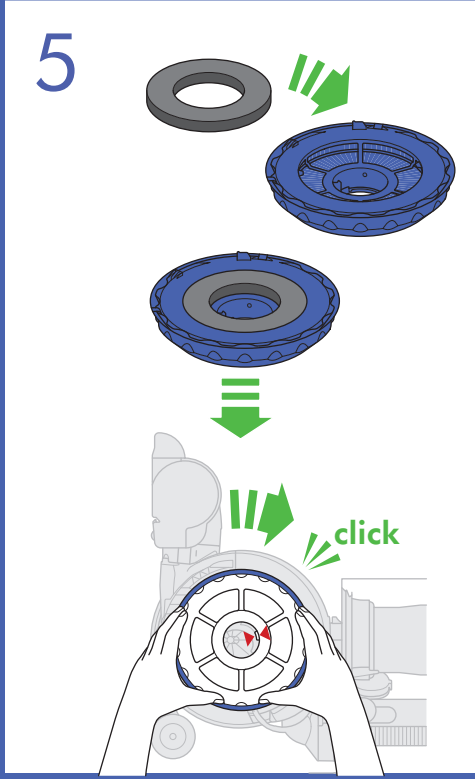
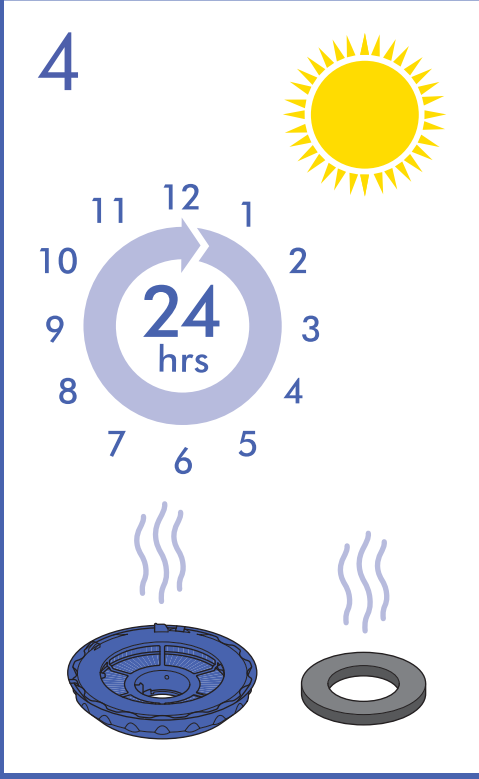
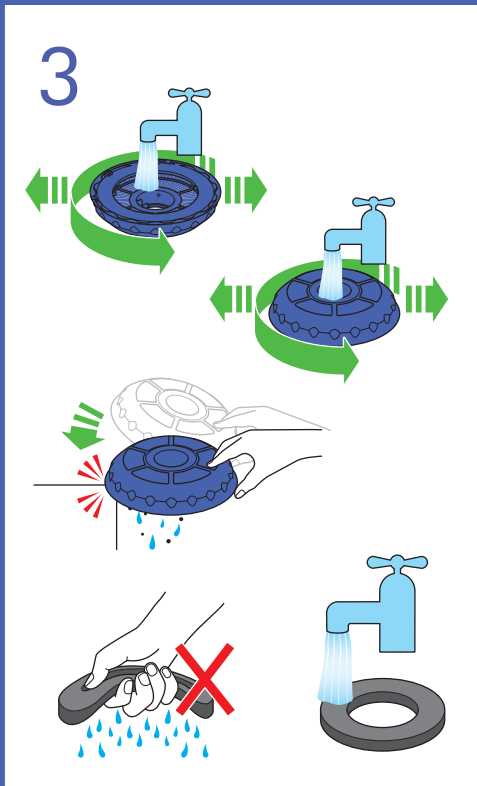
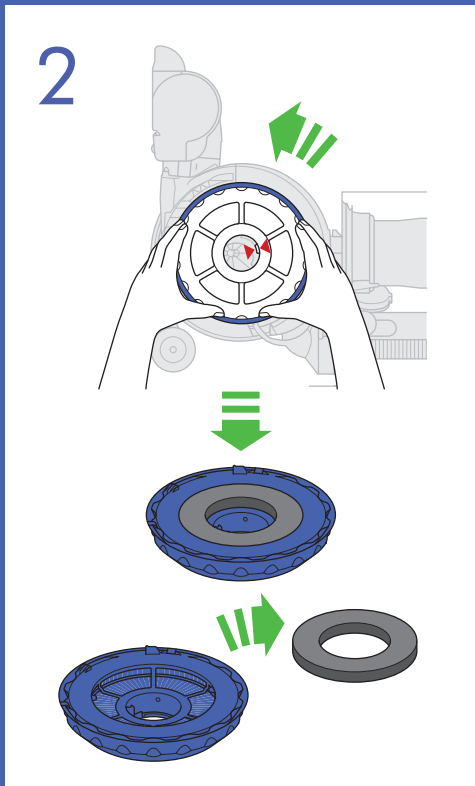
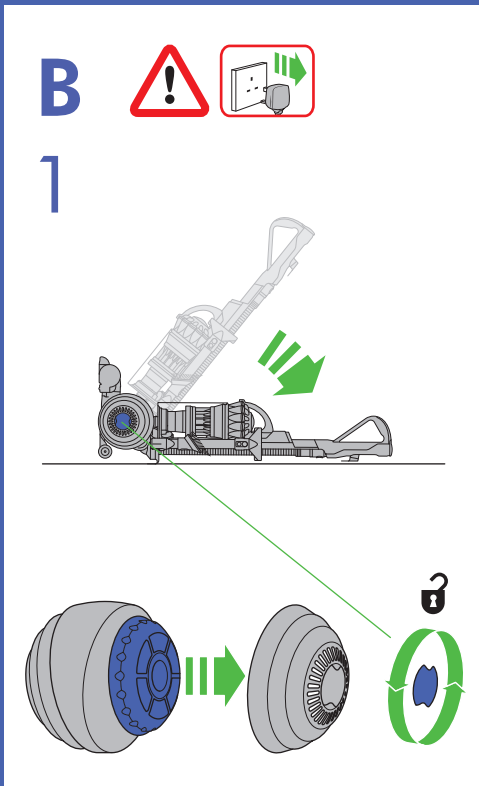

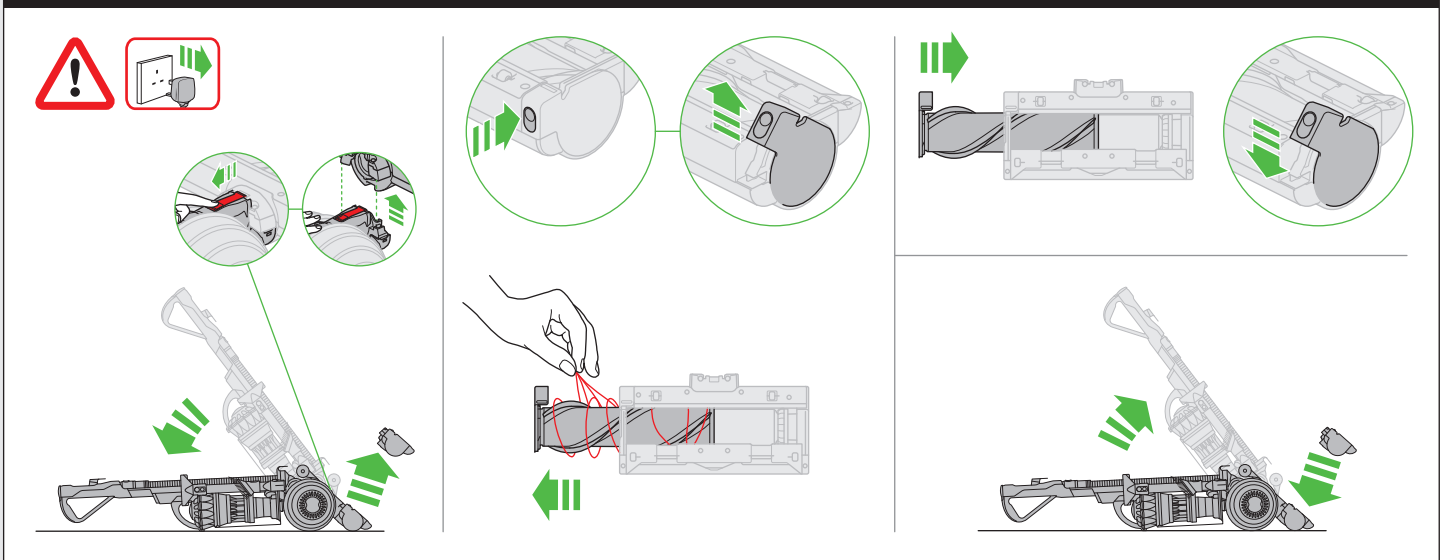

Using your Dyson appliance

Please read the 'Important Safety Instructions' in this Dyson operating manual before proceeding.

Assembly

- Lay the appliance on its back.
- Attach the cleaner head by sliding it on to the connections on the lower front part of the ball. Ensure the electrical plug on the cleaner head fits into the twin-block connection on the body of the appliance, which is directly above the airway. Push firmly: the cleaner head will click into place.
- Stand the appliance up straight.
- Attach the wand handle by sliding it on to the top of the appliance. The spring clip in the handle will click into place.
- Ensure the hose is straight. Press the red button on the hose. Slide the wand into the hose.
- Ensure the wand and hose sit in the recess of the handle. Slide the end of the wand down into the handle to secure it.
- Slide the tool holder onto the side of the duct as shown.
- Attach the tools as shown. In use, the tools can be attached to either the hose or the wand.
- Wind the cable around the cable hooks. Secure with the clip.

Operation

- Unwind the cable.
- Plug the appliance into the mains electricity supply.
- To switch 'ON' or 'OFF' press the red power button, located as shown.
- To use, recline the handle. The stabiliser stand will automatically lift up.
- After use, return the appliance to the upright position, pushing it firmly into place. The stabiliser wheels will automatically lower.
- Then unplug the appliance, coil the cable safely and put the appliance away.
- Switch 'OFF' the appliance, unplug and ensure it is upright before:
 - Changing or using tools.
 - Removing the hose or airway inspection parts.
- Use the cyclone carry handle to carry the machine.

Direct drive cleaner head with suction control

- This cleaner head is used for testing with the European Regulations: No. 665/2013 and No. 666/2013. Tested in Maximum suction for ground in dust and debris (+) level.



Maximum suction for ground in dust and debris (+)

- For vacuuming durable floor coverings, hard floors and heavily soiled carpets and rugs.
 - To switch to this setting, move the suction control slider on top of the cleaner head.
 - Before vacuuming your flooring, rugs and carpets, check the manufacturer's recommended cleaning instructions.

Suction for dust and debris (▲)

- For vacuuming of lightly soiled carpets, rugs and hard flooring.
- For vacuuming of large debris such as peanuts or rice.
 - Your appliance is pre-set to this level of suction when you take it out of the box.

Suction for deep pile carpets and delicate flooring (-)

- For vacuuming deep pile carpets or rugs and any flooring on which you may experience greater resistance.
- For vacuuming of lightly soiled floors, including delicate flooring such as vinyl, parquet and lino.
 - To switch to this setting, move the suction control slider on top of the cleaner head.

Attachments

- To release the wand, open the wand cap and pull the red tube up and away from the handle until it clicks into place.
- Should you wish to use the hose without the wand, follow the above instruction and press the red button to release the wand from the hose.

Carpets or hard floors

- The brush bar will always default to 'ON' (spinning) each time you switch the appliance 'ON' and recline it for cleaning.
- The brush bar will not rotate when the appliance is upright.
- To switch the brush bar 'OFF' (e.g. for hard surfaces, delicate rugs and delicate flooring):
 - Switch the appliance 'ON'.

- Recline the appliance.
- Press the brush bar 'ON/OFF' button – the brush bar will stop spinning.
- The brush bar will automatically stop if it becomes obstructed. See 'Brush bar – clearing obstructions'.
- Before vacuuming your flooring, rugs and carpets, check the manufacturer's recommended cleaning instructions.
- Some carpets may fuzz if a rotating brush bar is used when vacuuming. If this happens, we recommend vacuuming with the brush bar switched 'OFF' and consulting with the carpet manufacturer.
- The brush bar on the appliance may damage some carpet types. If you are unsure, turn 'OFF' the brush bar.
- Check the brush bar regularly and clear away any debris (such as hair). Debris left on the brush bar may cause damage to flooring when vacuuming.

Looking after your Dyson appliance

- Do not carry out any maintenance or repair work other than that shown in this Dyson Operating Manual, or advised by the Dyson Helpline.
- Only use parts recommended by Dyson. If you do not this could invalidate your guarantee.
- Store the appliance indoors. Do not use or store it below 3°C (37.4°F). Ensure the appliance is at room temperature before operating.
- Clean the appliance only with a dry cloth. Do not use any lubricants, cleaning agents, polishes or air fresheners on any part of the appliance.
- If used in a garage, always wipe the base plate and ball with a dry cloth after vacuuming to clean off any sand, dirt or pebbles that could damage delicate floors.

Vacuuming

- Do not use without the clear bin and filters in place.
- Fine dirt such as flour should only be vacuumed in very small amounts.
- Do not use the appliance to pick up sharp hard objects, small toys, pins, paper clips, etc. They may damage the appliance.
- When vacuuming, certain carpets may generate small static charges in the clear bin or wand. These are harmless and are not associated with the mains electricity supply. To minimize any effect from this small static charge, do not put your hand or insert any object into the clear bin unless you have emptied it first, then cleaned it with a damp cloth (see 'Cleaning the clear bin').
- Do not put the appliance on chairs, tables, etc.
- Before vacuuming highly polished floors, such as wood or lino, first check that the underside of the floor tool and its brushes are free from foreign objects that could cause marking.
- Do not leave the cleaner head in one place on delicate floors.

Emptying the clear bin

- Empty as soon as the dirt reaches the level of the MAX mark – do not overfill.
- Switch 'OFF' and unplug before emptying the clear bin.
- To remove the cyclone and clear bin unit, press down on the red button on the top of the carrying handle on the cyclone.
- To release the dirt, press all the way down on the same red button on the top of the carrying handle on the cyclone.
- To minimise dust/allergen contact when emptying, encase the clear bin tightly in a plastic bag and empty.
- Remove the clear bin carefully from the bag.
- Seal the bag tightly, dispose as normal.
- To refit:
 - Ensure the airway in the bin base is clear of dust and dirt.
 - Close the clear bin base so it clicks into place.
 - Push the cyclone and clear bin unit into the main body of the appliance; it will click into place.
 - Ensure the cyclone and clear bin unit is secure.

Cleaning the clear bin

- Before cleaning the clear bin, follow 'Emptying the clear bin' instructions.
- To remove the cyclone unit from the clear bin press the red bin release button. This exposes a small silver button behind the opening mechanism. Press the silver button and separate the cyclone unit from the clear bin.
- Do not use detergents, polishes or air fresheners to clean the clear bin.
- Do not put the clear bin in a dishwasher.
- Do not immerse the cyclone in water or pour water into the cyclones.
- Clean the cyclone shroud with a damp cloth only.
- Ensure the clear bin is completely dry before replacing.

Washing your filters

- Your appliance has two washable filters, located as shown on the front page.
- Check and wash the filters regularly according to instructions to maintain performance.
- Switch 'OFF' and unplug before checking or removing the filters.
- The filters may require more frequent washing if vacuuming fine dust or carpet cleaning powders.
- Wash with cold water only. Do not use detergents.
- Do not put the filters in a dishwasher, washing machine, tumble dryer, oven, microwave or near a naked flame.

Filter A

- Remove the cyclone and clear bin (see 'Emptying the clear bin').
- Release the catch on the front of the cyclone handle and then remove the filter.
- Wash the filter with cold water only. Hold under a tap and run water through the open end until the water runs clear. Turn upside down and tap out.
- Run water over the outside of the filter until the water runs clear.
- Squeeze and twist with both hands to make sure the excess water is removed.
- Stand the filter on its wide, open end to dry. Leave to dry completely for a minimum of 24 hours.
- Replace the filter into the cyclone. Swing the handle back into place. Ensure the latch clicks to engage and is secure. Fit the cyclone and clear bin unit onto the appliance (instructions above).

Filter B

Filter B is a two part filter; an inner foam ring and an outer filter and shell.

- Lay the appliance on its side.
- To remove filter B:
 - Turn the blue central locking dial on the outer cover of the ball anti-clockwise until the cover is released.
 - Lift off the ball shell cover.
 - Turn the outer filter one-quarter anti-clockwise to release.
- Separate the inner foam ring from the outer filter and shell. Wash both the inner and outer filter with cold water only. No hot water and no detergents.
- The outer filter and shell should be rinsed on all sides and tapped out until the water runs clear, then tapped out again to ensure all excess water is removed. (Tap on the plastic rim, not the filter material.) Leave to dry completely for a minimum of 24 hours.
- Run water over the inner foam ring until the water runs clear.
- Leave the filter to dry completely for a minimum of 24 hours.
- It is normal for the filter in the ball to turn grey in colour.
- To refit filter B:
 - Refit the inner foam ring onto the outer filter and shell.
 - Refit the outer filter on to the ball.
 - Secure the filter by turning it clockwise so the arrows align.
- When refitting the outer cover of the ball, keep turning the central locking dial clockwise. It is locked once it starts to click.

Blockages – thermal cut-out

- This appliance is fitted with an automatically resetting thermal cut-out.
- Large items may block the tools or wand inlet. If any part becomes blocked the appliance may overheat and automatically cut-out.
- If this happens, follow the instructions in 'Looking for blockages'.
- NOTE: Large items may block the tools or wand inlet. If this happens, do not operate the wand release catch. Switch 'OFF' and unplug. Failure to do so could result in personal injury.

Looking for blockages

- Switch 'OFF' and unplug before looking for blockages. Failure to do so could result in personal injury.
- Leave to cool down for 1-2 hours before checking the filters or for blockages.
- Clear any blockage before restarting.
- Look for blockages in the wand, airways and cleaner head.
- To release the hose from the machine, you will need to remove the wand.
- Open the wand release cap.
- Pull the wand up and away from the handle.
- Press the red release button in the connecting collar and remove the wand from the hose.
- Remove the clear bin and cyclone unit. Then release the hose from the appliance by pressing the red tab on the base of the hose – you can see it from the front of the appliance.
- Check for blockages in the hose.
- Beware of sharp objects when checking for blockages.
- To refit the hose, align the guides on the base of the hose with the channels in the neck of the airway. Ensure the red tab faces the front of the appliance. Push the hose on. It will click into place. To refit the wand follow the instructions above in the 'Assembly' section.
- To look for blockages in the front airway between the ball and the cleaner head you will need to remove the cleaner head: see 'Cleaner head maintenance' section on how to do this.
- To look for blockages in the rear airway between the ball and the cleaner head you will need to release the hose. Hold and slide the red cuff out. Check thoroughly for blockages and slot back into place.
- Beware of sharp objects when checking for blockages.
- Refit all parts securely before using.
- Clearing blockages is not covered by your guarantee.

Brush bar – clearing obstructions

- If your brush bar is obstructed, it may shut 'OFF'. If this happens, you will need to remove the blockage.
- Switch 'OFF' and unplug before proceeding. Failure to do so could result in personal injury.
- Beware of sharp objects when clearing obstructions.
- If you still cannot clear the obstruction, please follow the instructions below to remove the brush bar. This gives more access to the obstruction. Alternatively, contact a Dyson expert on the Dyson helpline or visit the website.
- Clearing brush bar obstructions is not covered by your guarantee.

Cleaner head maintenance

- Switch 'OFF' and unplug before proceeding. Failure to do so could result in personal injury.
- Lay the appliance on its front.
- There is a red latch on the connection between the ball and cleaner head. Slide it towards the ball, supporting the appliance as you do so.
- Pull the cleaner head away from the appliance. Use a constant, firm pressure.
- Beware of sharp objects when clearing obstructions.
- There is a silver button on the back of the cleaner head. Press it down and rotate the end cap to the open position and place it aside. Gently slide the cylindrical brush bar out from the cleaner head.

- Remove any debris such as hair from the brush bar.
- Slide the brush bar back into the cleaner head. Place the end cap back on at a 45° angle and twist upwards.
- Lay the appliance on its back.
- Attach the cleaner head by sliding it on to the connections on the lower front part of the ball. Ensure the electrical plug on the cleaner head fits into the twin-block connection on the body of the appliance, which is directly above the airway. Push firmly: the cleaner head will click into place.

Disposal information

- Dyson products are made from high grade recyclable materials. Recycle where possible.
-  This marking indicates that this product should not be disposed with other household wastes throughout the EU. To prevent possible harm to the environment or human health from uncontrolled waste disposal, recycle it responsibly to promote the sustainable reuse of material resources. To return your used device, please use the return and collection systems or contact the retailer where the product was purchased. They can take this product for environmentally safe recycling.

Online support

- For online help, general tips, videos and useful information about Dyson.
UK - www.dyson.co.uk/support
ROI - www.dyson.ie/support
- **Compatibility with previous Dyson tools and accessories**
Your new machine comes with the latest Dyson technology. As such it is equipped with the latest Quick release catches that allow quick and easy tool or accessory changes. However, this makes it incompatible with previous generations of Dyson products.
- An adaptor which makes your new machine compatible with older Dyson tools and accessories is available by contacting your local Dyson Helpline (see 'Dyson Customer Care' section for contact details).

Guarantee terms and conditions

Dyson customer care

Thank you for choosing to buy a Dyson appliance.

After registering your 5 year guarantee, your Dyson appliance will be covered for parts and labour for 5 years from the date of purchase, subject to the terms of the guarantee. If you have any queries regarding your Dyson appliance, visit www.dyson.co.uk/support (UK) or www.dyson.ie/support (ROI) for online help, general tips and useful information about Dyson. Alternatively, you can call the Dyson Helpline with your serial number and details of where/when you bought the appliance. If your Dyson appliance needs a repair, call the Dyson Helpline so we can discuss the available options. If your Dyson appliance is under guarantee, and the repair is covered, it will be repaired at no cost.

Please register as a Dyson appliance owner

To help us ensure you receive prompt and efficient service, please register as a Dyson appliance owner. There are three ways to do this:

- Online at www.dyson.co.uk/register (UK) or www.dyson.ie/register (ROI).
- Telephone the Dyson Helpline on 0800 298 0298 (UK) or 01 475 7109 (ROI).
- Complete the enclosed form and post it to us. This will confirm ownership of your Dyson appliance in the event of an insurance loss, and enable us to contact you if necessary.
- By registering online or by phone you will:
 - Protect your investment with a two year parts and labour guarantee.
 - Receive helpful tips on using your machine.
 - Get expert advice from the Dyson Helpline.

– Be the first to hear about our latest inventions.

- Registering only takes a few minutes and all you need is your serial number.

Limited 5 year guarantee

Terms and conditions of the Dyson 5 year limited guarantee.

What is covered

- The repair or replacement of your Dyson machine (at Dyson's discretion) if it is found to be defective due to faulty materials, workmanship or function within 5 years of purchase or delivery (if any part is no longer available or out of manufacture Dyson will replace it with a functional replacement part).
- Where this appliance is sold outside of the EU, this guarantee will only be valid if the appliance is used in the country in which it was sold.
- Where this appliance is sold within the EU, this guarantee will only be valid (i) if the appliance is used in the country in which it was sold or (ii) if the appliance is used in Austria, Belgium, France, Germany, Ireland, Italy, Netherlands, Spain or the United Kingdom and the same model as this appliance is sold at the same voltage rating in the relevant country.

What is not covered

Dyson does not guarantee the repair or replacement of a product where a defect is the result of:

- Accidental damage, faults caused by negligent use or care, misuse, neglect, carelessness or operation or handling of the appliance which is not in accordance with the Dyson Operating Manual.
- Use of the appliance for anything other than normal domestic household purposes.
- Use of parts not assembled or installed in accordance with the instructions of Dyson.
- Use of parts and accessories which are not genuine Dyson components.
- Faulty installation (except where installed by Dyson).
- Damage from external sources such as transit, weather, electrical outages or power surges.
- Repairs or alterations carried out by parties other than Dyson or its authorised agents.
- Blockages – please refer to the Dyson Operating Manual for details of how to look for and clear blockages.
- Normal wear and tear (e.g. fuse, brush bar etc.).
- Damage as a result of use not in accordance with the rating plate.
- Use of this appliance on rubble, ash, plaster.
- Additionally, this limited guarantee does not apply to any appliance that has had the serial number altered or removed. If you are in any doubt as to what is covered by your guarantee, please contact the Dyson Helpline.

Summary of cover

- The guarantee becomes effective at the date of purchase (or the date of delivery if this is later).
- You must provide proof of (both the original and any subsequent) delivery/purchase before any work can be carried out on your Dyson appliance. Without this proof, any work carried out will be chargeable. Keep your receipt or delivery note.
- All work will be carried out by Dyson or its authorised agents.
- Any parts which are replaced by Dyson will become the property of Dyson.
- The repair or replacement of your Dyson appliance under guarantee will not extend the period of guarantee.
- The guarantee provides benefits which are additional to and do not affect your statutory rights as a consumer.

Important data protection information

- Your information will be held by Dyson and its agents for promotional, marketing and servicing purposes.
- If your personal details change, if you change your mind about any of your marketing preferences or if you have any queries about how we use your information, please contact the Dyson Helpline.
- For more information on how we protect your privacy, please see our privacy policy on the Dyson website.

Product information

Please note: Small details may vary from those shown.

Important!



Wash filters

Wash filters with cold water at least once every month.
The filters may require more frequent washing if vacuuming fine dust.



Dyson Customer Care

If you have a question about your Dyson appliance, call the Dyson Customer Care Helpline with your serial number and details of where and when you bought the appliance, or contact us via the Dyson website.

Dyson contact details

UK:

Website: www.dyson.co.uk/support
Dyson helpline: 0800 298 0298
Email: askdyson@dyson.co.uk
Address: Dyson Technology Limited, Tetbury Hill, Malmesbury, Wiltshire, SN16 0RP

ROI:

Website: www.dyson.ie/support
Dyson helpline: 01 475 7109
Email: askdyson@dyson.co.uk
Address: Dyson Ireland Limited, Office 2, Central Park, Leopardstown, Dublin 18, Ireland





GUARANTEE FORM

Serial number

Date of purchase / / Country of purchase UK ROI

Title Surname

First name

Address

Postcode

e-mail

Telephone Mobile

As a Dyson appliance owner, you can hear about Dyson inventions, services and products before anyone else. If it's okay to contact you, please let us know how we may do this.

By mail Yes No

By phone Yes No

By email Yes No

By text message Yes No

We sometimes ask other companies (such as market researchers) to contact owners on our behalf. We do this to get feedback on ideas or ask you to try new products and services. Would this be okay?

Yes No

3 EASY WAYS TO REGISTER YOUR FREE 5 YEAR GUARANTEE

REGISTER ONLINE 

Visit our website to register your full parts and labour guarantee online.

www.dyson.co.uk/register
www.dyson.ie/register

REGISTER BY PHONE 

Call our dedicated helpline. Open Monday to Friday 8am-8pm & Saturday and Sunday 8am-6pm.

UK: 0800 298 0298
 ROI: 01 475 7109

REGISTER BY MAIL 

Complete and return the form to Dyson in the envelope supplied.

