

dyson **csys**

Operating manual

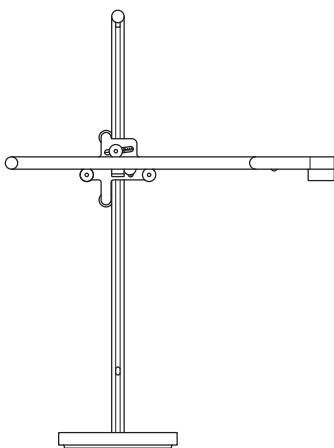

CD05

Contents

Getting started

- 4 Registration
- 6 Important safety instructions
- 8 Assembly
- 10 Controls
- 12 Colour temperature
- 14 Brightness
- 16 Settings
- 18 Disabling/Enabling Bluetooth® wireless technology
- 19 USB-C Charging point

Additional information

- 20 Dyson Link app connectivity
- 20 Disposal
- 20 Terms and conditions of the Dyson 5 year guarantee
- 22 Important data protection information
- 22 Important information

Thank you for choosing to buy a Dyson light



Download the latest Dyson Link app from
the App Store or Google Play.

Open the app and follow the on screen
instructions to connect to your light.



Online

UK: www.dyson.co.uk/support

ROI: www.dyson.ie/support



On the phone:

0800 345 7788

Monday - Friday 8am-6pm



Apple and the Apple logo are trademarks of Apple Inc., registered in the U.S. and other countries. App Store is a service mark of Apple Inc., registered in the U.S. and other countries. Google Play and the Google Play logo are trademarks of Google Inc.



The Bluetooth® word mark and logos are registered trade marks owned by the Bluetooth SIG, Inc. and any use of such marks by Dyson is under license.

Registration

After registering your 5 year guarantee, your Dyson light will be covered for parts and labour for 5 years from the date of purchase, subject to the terms of the guarantee.

If you have any questions about your Dyson light, call the Dyson Helpline with your serial number and details of where and when you bought the light.

Most questions can be solved over the phone by one of our trained Dyson Helpline staff.

Your serial number can be found on the base of the light.

Visit www.dyson.co.uk/support (UK) or www.dyson.ie/support (ROI) for online help, support videos, general tips and useful information about Dyson.

Note your serial number for future reference.

This illustration is for example purposes only.





Register with your smartphone

Download the Dyson Link app and you will be taken through registration as part of the set up.



Register online

Visit our website to register your full parts and labour guarantee online.

www.dyson.co.uk/register

www.dyson.ie/register



Register by phone

Call our dedicated Helpline.

Open Monday - Friday 8am-6pm.

0800 345 7788

IMPORTANT SAFETY INSTRUCTIONS

BEFORE USING THIS LIGHT READ ALL INSTRUCTIONS AND CAUTIONARY MARKINGS IN THIS MANUAL AND ON THE LIGHT

When using any electrical appliance, basic precautions should always be followed, including the following:

WARNING

These warnings apply to the light, and also where applicable to chargers or mains adaptors.

TO REDUCE THE RISK OF FIRE, ELECTRIC SHOCK, OR INJURY:

1. This Dyson light can be used by persons with reduced physical, sensory or reasoning capabilities, or lack of experience and knowledge, only if they have been given supervision or instruction by a responsible person concerning use of the light in a safe way and understand the hazards involved. Cleaning and maintenance shall not be performed by children.
2. Do not allow to be used as a toy. Close attention is necessary when the light is used near children.
3. Ensure light is fully assembled in line with the instructions before use.
4. Suitable for indoor use only 0°C (32°F) – 40°C (104°F).
5. Use only as described in this Dyson Operating Manual. Do not carry out any maintenance other than that advised by the Dyson Helpline.
6. If the light is not working as it should, has received a sharp blow, has been dropped,

- damaged, left outdoors, or dropped into water, do not use and contact the Dyson Helpline.
7. If a service or repair is needed, contact the Dyson Helpline so we can discuss the available options. Do not disassemble the light as incorrect reassembly may result in an electric shock or fire.
 8. Do not handle any part of the light, cable or plug with wet hands.
 9. Do not use with a damaged cable or plug. If the supply cable is damaged it must be replaced by Dyson, its service agent or similarly qualified persons in order to avoid a hazard.
 10. Do not stretch the cable or place the cable under strain. Keep cable away from heated surfaces.
 11. Do not route the cable under furniture or appliances. Do not cover cable with throw rugs, runners or similar coverings. Arrange cable away from traffic area and where it will not be tripped over.
 12. Do not unplug by pulling on the cable. To unplug, grasp the plug, not the cable. The use of an extension cable is not recommended.
 13. Turn off all controls before unplugging. Unplug from socket when not in use for extended periods. To avoid a tripping hazard, safely coil the cable.
 14. Do not use near furnaces, fireplaces, stoves or other high temperature heat sources.
 15. The light source is not replaceable; when the light source reaches its end of life, the whole light shall be replaced. End of life replacement is not covered under the guarantee.

READ AND SAVE THESE INSTRUCTIONS

Assembly

1

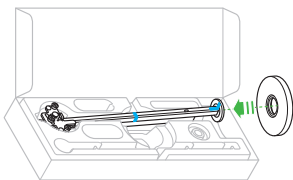

2

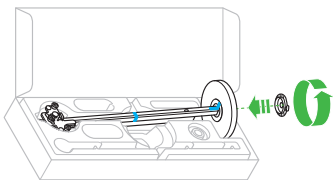

3

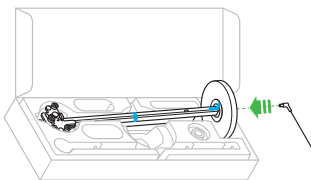

4

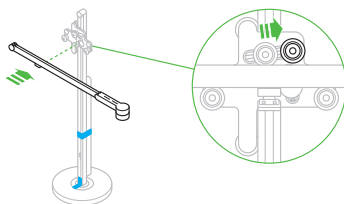

It is important that the light is assembled in the box as shown.
Do not remove the transit tape until the light is fully assembled.

5

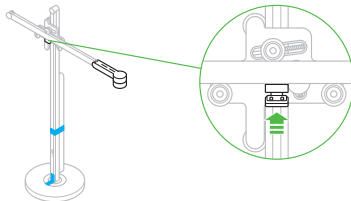

6

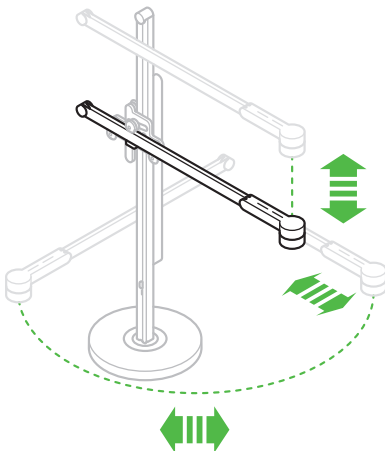
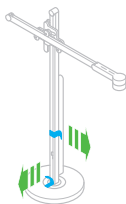

Controls

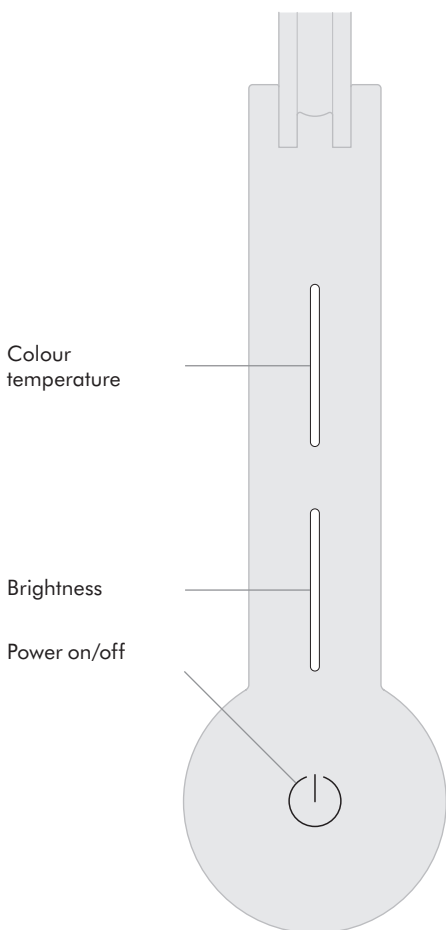

Controls

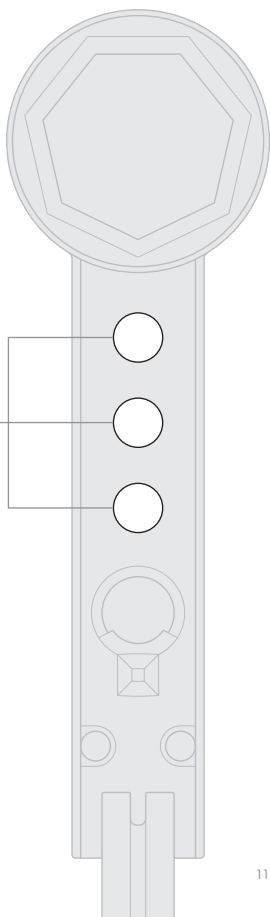

Colour temperature

Swipe to change the colour temperature of the light from warm through to cool.

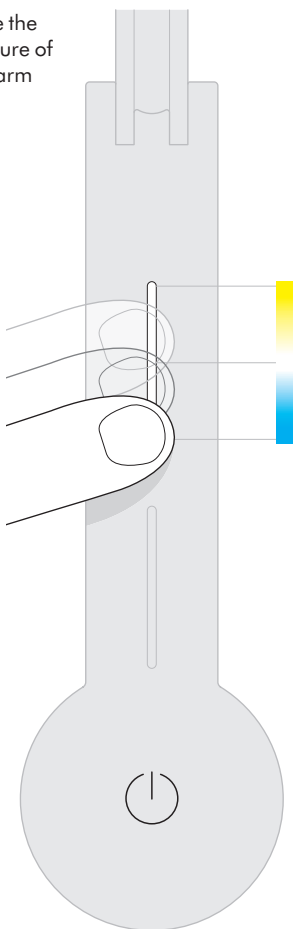

To find out more about colour temperatures of light, and to get the most from your light, go to the Dyson Link app or online at www.dyson.co.uk or www.dyson.ie

Tap to change quickly between colour temperatures.

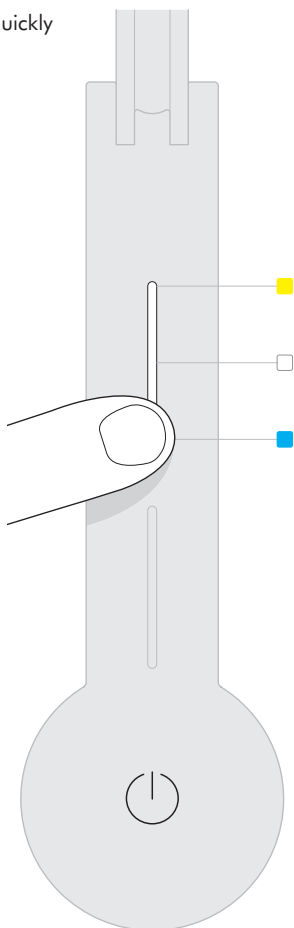

Brightness

Swipe to change
the brightness of
the light.

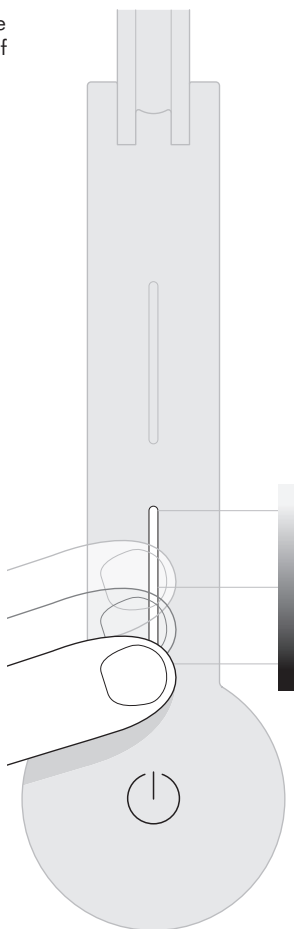

To find out more about brightness levels and to get the best from your light, go to the Dyson Link app or online at www.dyson.co.uk or www.dyson.ie

Tap to change quickly between brightness levels.

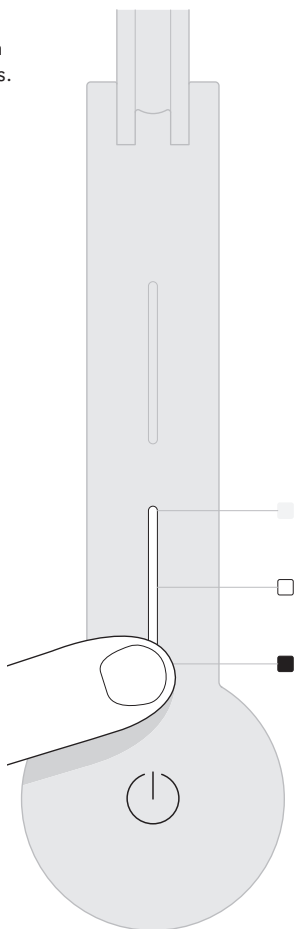

Settings



Automatically changes the brightness and colour, according to your geographical location, throughout the day when connected by Bluetooth® wireless technology to the Dyson Link app.



The light will turn off after 2 minutes if no presence is detected.



AUTO

The light will adjust to background light conditions and keep the workspace at a constant brightness.

For more information about using your light without connecting to the Dyson Link app:
www.dyson.co.uk/support or www.dyson.ie/support

To find out more about settings, and to get the most from your light, go to the Dyson Link app or online at www.dyson.co.uk or www.dyson.ie

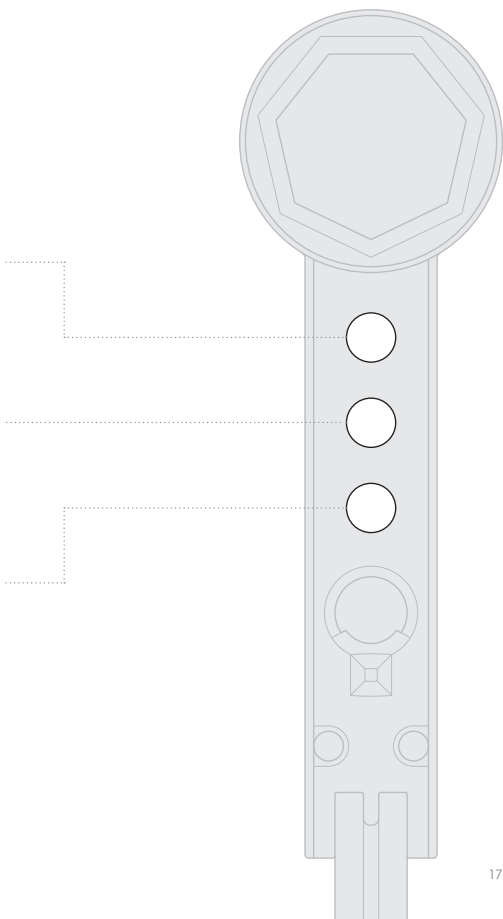

Disabling/Enabling Bluetooth® wireless technology

The light has Bluetooth® wireless technology enabled by default.

Press and hold the middle button until the LED lights on the three buttons blink. The main light source will turn off and then on again to show that Bluetooth has been disabled.

To re-enable Bluetooth, repeat the instructions above. The main light will blink twice to show that Bluetooth has been re-enabled.

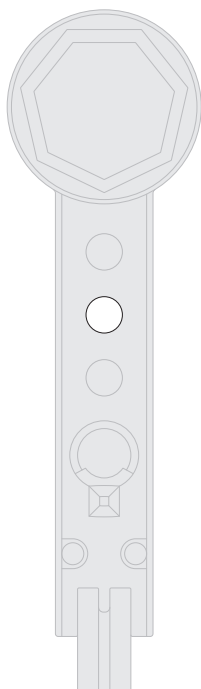

USB-C charging point



Plug in your mobile devices to charge up to 1.5A at 5V.

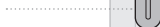

Additional information

DYSON LINK APP CONNECTIVITY

- Dyson endeavours to ensure that our technology is compatible with current operating systems but this is not guaranteed. If you have any questions or would like to check the latest compatibility, please contact the Dyson Helpline.
- Your mobile device must have Bluetooth 4.0 support (Bluetooth Low Energy) in order to set up a connection with the light. Check your device specification for compatibility.

DISPOSAL

- Dyson products are made from high grade recyclable materials. Recycle where possible.
- Dispose in accordance with local ordinances or regulations.



This marking indicates that this product should not be disposed with other household wastes throughout the EU. To prevent possible harm to the environment or human health from uncontrolled waste disposal, recycle it responsibly to promote the sustainable reuse of material resources. To return your used device, please use the return and collection systems or contact the retailer where the product was purchased. They can take this product for environmentally safe recycling.

LIMITED 5 YEAR GUARANTEE

TERMS AND CONDITIONS OF THE DYSON 5 YEAR LIMITED GUARANTEE.

WHAT IS COVERED

- The repair or replacement of your Dyson light (at Dyson's discretion) if it is found to be defective due to faulty materials, workmanship or function within 5 years of purchase or delivery (if any part is no longer available or out of manufacture Dyson will replace it with a functional replacement part).
- Where this light is sold outside of the EU, this guarantee will only be valid if the light is used in the country in which it was sold.

- Where this light is sold within the EU, this guarantee will only be valid (i) if the light is used in the country in which it was sold or (ii) if the light is used in Austria, Belgium, France, Germany, Ireland, Italy, Netherlands, Spain or the United Kingdom and the same model as this light is sold at the same voltage rating in the relevant country.

WHAT IS NOT COVERED

Dyson does not guarantee the repair or replacement of a light where a defect is the result of:

- Damage caused by not carrying out any recommended maintenance of the light.
 - Accidental damage, faults caused by negligent use or care, misuse, neglect, carelessness, operation or handling of the light which is not in accordance with the Dyson Operating Manual.
 - Use of the light for anything other than the use it is designed for.
 - Use of parts not assembled or installed in accordance with the instructions of Dyson.
 - Use of parts and accessories which are not genuine Dyson components.
 - Faulty installation (except where installed by Dyson).
 - Repairs or alterations carried out by parties other than Dyson or its authorised agents.
 - Normal wear and tear (e.g. fuse etc.).
- If you are in any doubt as to what is covered by your guarantee, please contact the Dyson Helpline.

SUMMARY OF COVER

- The guarantee becomes effective from the date of purchase (or the date of delivery if this is later).
- You must provide proof of (both the original and any subsequent) delivery/purchase before any work can be carried out on your Dyson light. Without this proof, any work carried out will be chargeable. Keep your receipt or delivery note.
- All work will be carried out by Dyson or its authorised agents.

- Any parts which are replaced by Dyson will become the property of Dyson.
- The repair or replacement of your Dyson light under guarantee will not extend the period of guarantee.
- The guarantee provides benefits which are additional to and do not affect your statutory rights as a consumer.

IMPORTANT DATA PROTECTION INFORMATION

You will need to provide us with basic contact information when you register your Dyson Product or the Dyson Link app;

WHEN REGISTERING VIA THE DYSON LINK APP

You will need to provide us with basic contact information to register the Dyson Link app; this enables us to securely link your product to your instance of the app.

WHEN REGISTERING YOUR DYSON LIGHT:

- You will need to provide us with basic contact information to register your product and enable us to support your guarantee.
- When you register, you will have the opportunity to choose whether you would like to receive communications from us. If you opt-in to communications from Dyson, we will send you details of special offers and news of our latest innovations.
- We never sell your information to third parties and only use information that you share with us as defined by our privacy policies which are available on our website at privacy.dyson.com

CONFORMITY INFORMATION

2402MHz - 2482MHz, 10mW max

Hereby, Dyson declares that this product is in compliance with the essential requirements and other relevant provisions of Directive 2014/53/EU.
EC Declaration of Conformity:

www.dyson.co.uk/inside-dyson/terms/compliance

Dyson customer care

If you have a question about your Dyson light, call the Dyson Helpline with your serial number and details of where and when you bought the light, or contact us via the Dyson website.

Dyson contact details

UK

www.dyson.co.uk

0800 345 7788

askdyson@dyson.co.uk

Dyson Technology Limited, Tetbury Hill,
Malmesbury, Wiltshire, SN16 0RP

ROI

www.dyson.ie

0800 345 7788

askdyson@dyson.ie

Dyson Ireland Limited, Office 2, Central Park,
Leopardstown, Dublin 18, Ireland

www.dyson.co.uk

www.dyson.ie

JN.94644 PN.267464-08-02 14.09.18